

DC-INDUSTRIE2 |

Nov. 2022

# DC-INDUSTRIE2 – open DC grid for sustainable factories

Joint research project: DC-INDUSTRIE2 – Direct current for the factory of the future

Contact:

Dr. Hartwig Stammberger  
(Eaton, Bonn, project coordinator)

Prof. Dr.-Ing. Holger Borchering  
(TH OWL, Lemgo, scientific lead of the project)

Supported by:



on the basis of a decision  
by the German Bundestag

## Overview: research project DC-INDUSTRIE2

- **Funded by the German Federal Government**
  - Funding codes: 03EI6002A-Q
- **3.5 years until March 2023**
- **39 industry and research partners**
  - Some 140 engineers & researchers
- **Objectives:**
  - Safe and robust energy supply for production
  - Mains-supporting connection to the supply grid
  - Maximum use of decentralized, regenerative energy
  - Simple project planning
- **Implementation and validation**
  - 10 model plants and transfer centers

on the basis of a decision  
by the German Bundestag

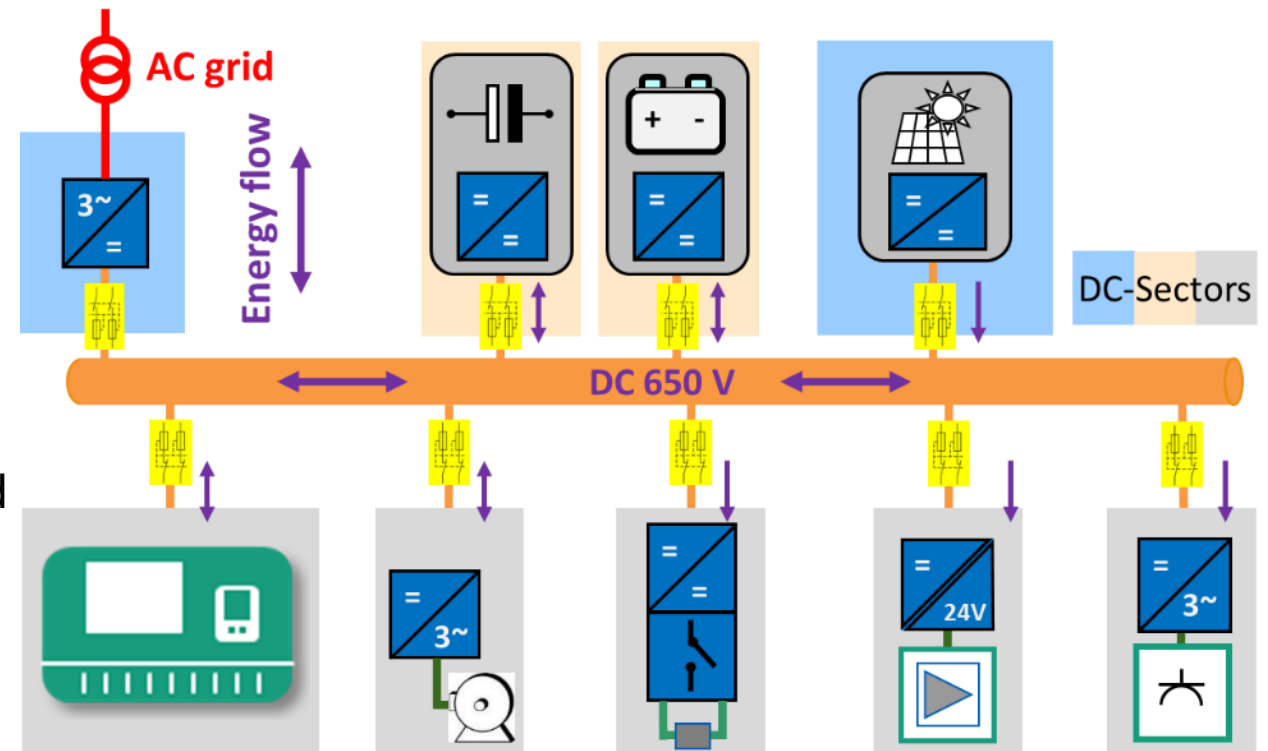

## Status quo: Topology of an industrial AC grid

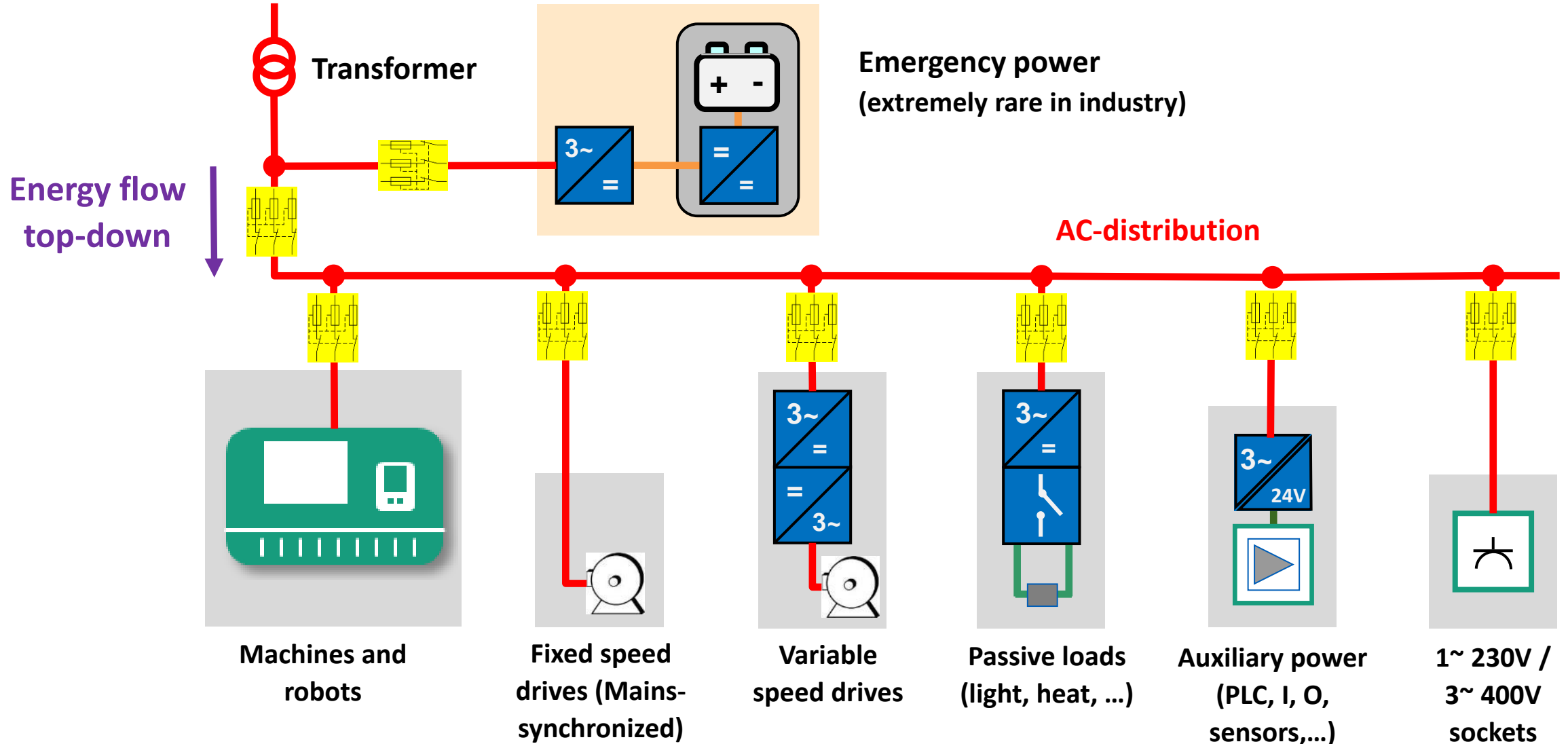

## Energy: Current situation with frequency converters (AC-AC)

Basic wiring of frequency converters is optimized for **motor** applications

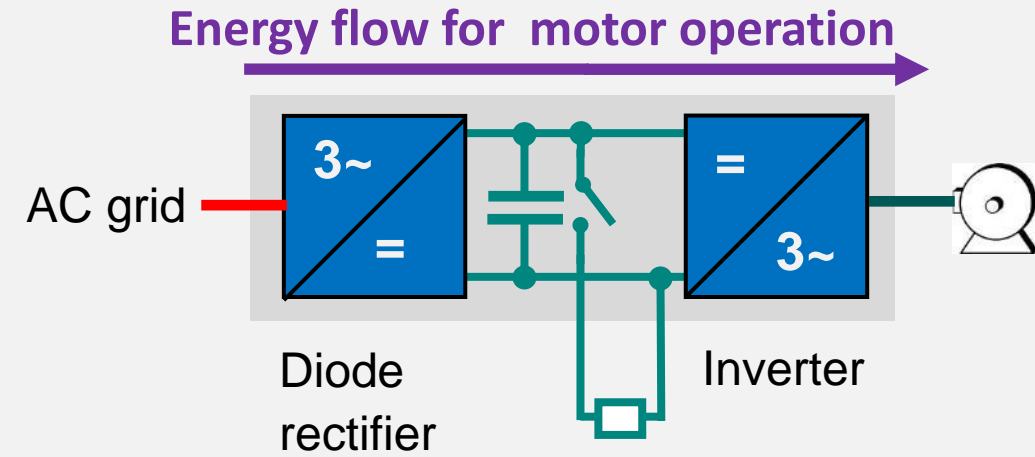

In **braking** mode, the inverter needs to dispose of the stored energy. The most common method is the **dissipation of the energy to heat in braking resistors**

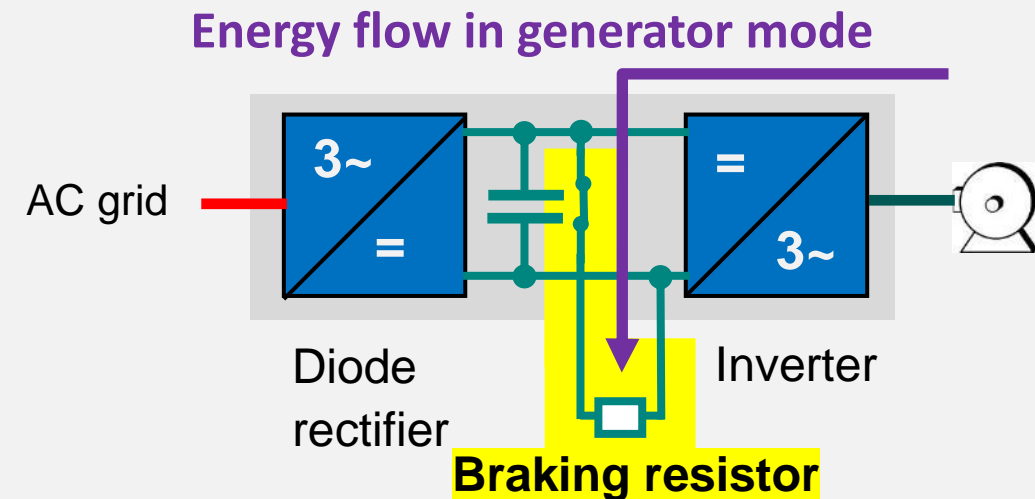

## Topology of an industrial DC grid

Many AC applications already use DC internally

- For example, frequency converters
- Connecting the DC links with each other makes the many AC-to-DC conversion steps redundant.

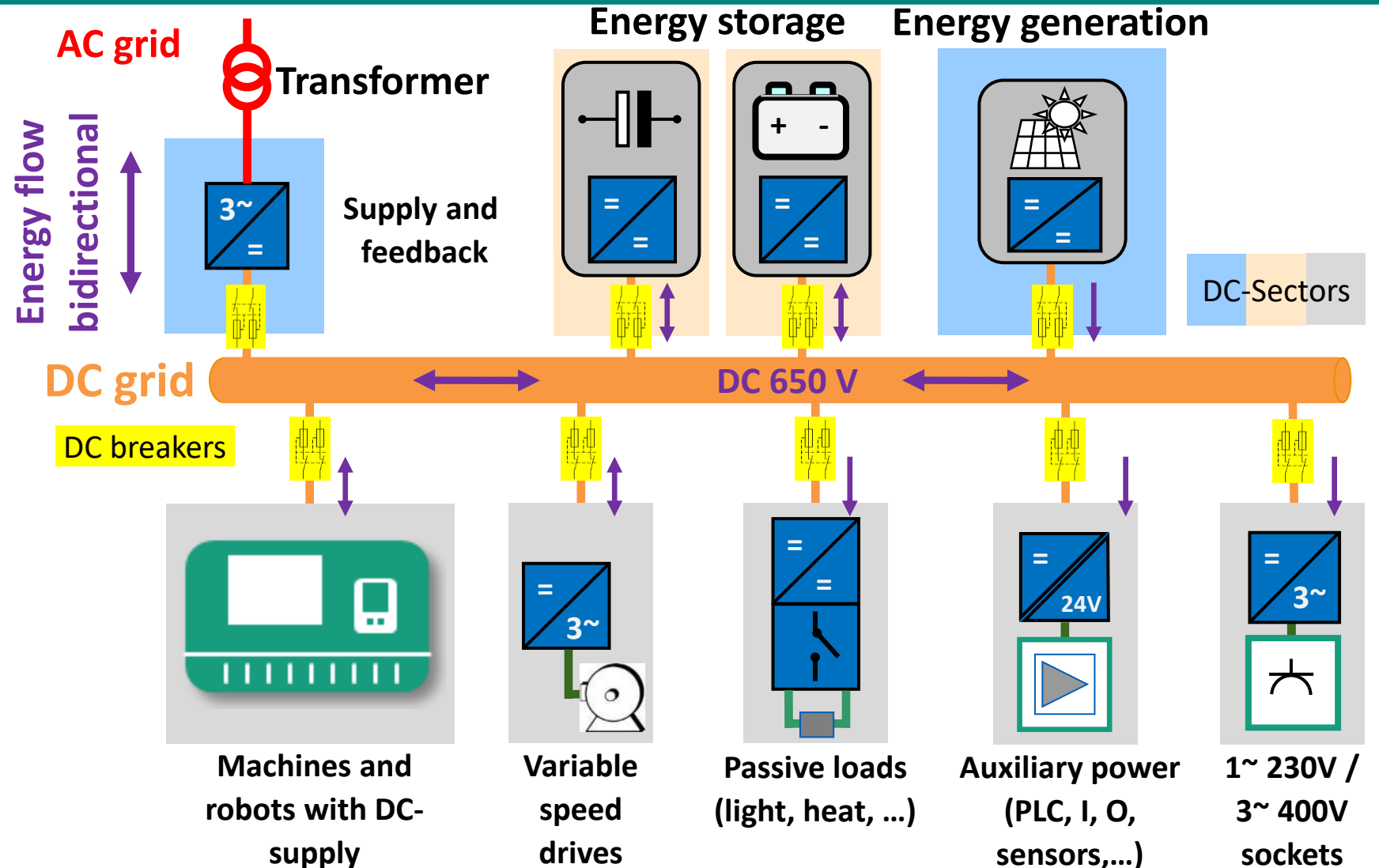

# Electrical energy exchange with a DC grid

## DC grid

- Reduces effort
- Enables direct energy exchange – no additional components needed

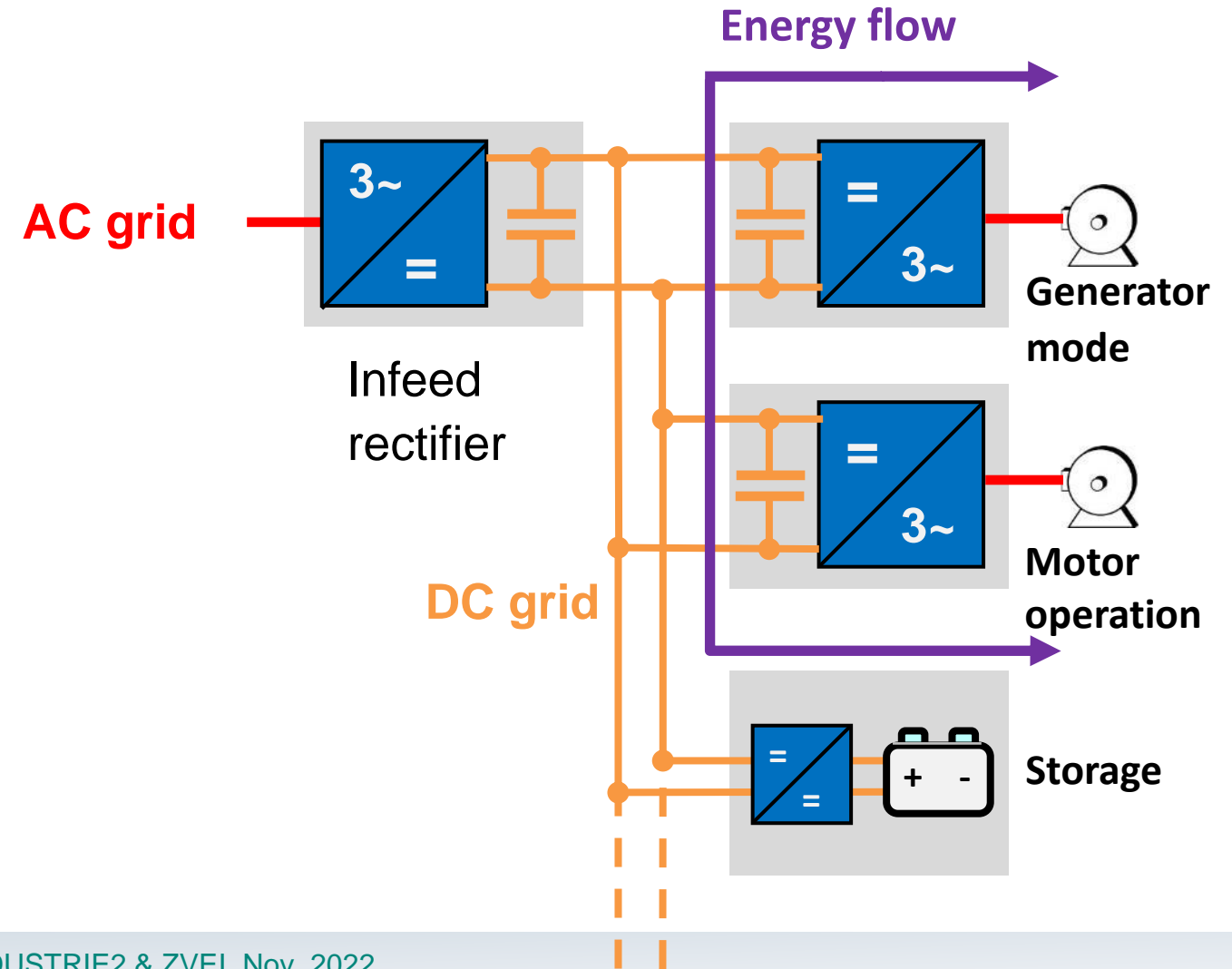

# Advantages of DC grid for industrial plants

## • Energy efficiency

- Lower losses (typically 2-4% \*)
- Total recovery of braking energy \*
- Direct use of renewable energy sources \*
- Peak power reduction through suitable storage (up to 80%) \*

## • Resource efficiency

- Reduction of copper use and power loss (cables)
- Lower equipment costs and space savings in the field

## • Grid stability

- Additional investments for mains filtering and compensation can be omitted, and existing grids are supported
- Production failures through mains disturbances can be prevented / reduced

## • Industrial Smart DC-Grid / flexibility

- Infrastructure for intelligent control of energy flows enables advantages in energy purchasing
- Supports modular machine concepts

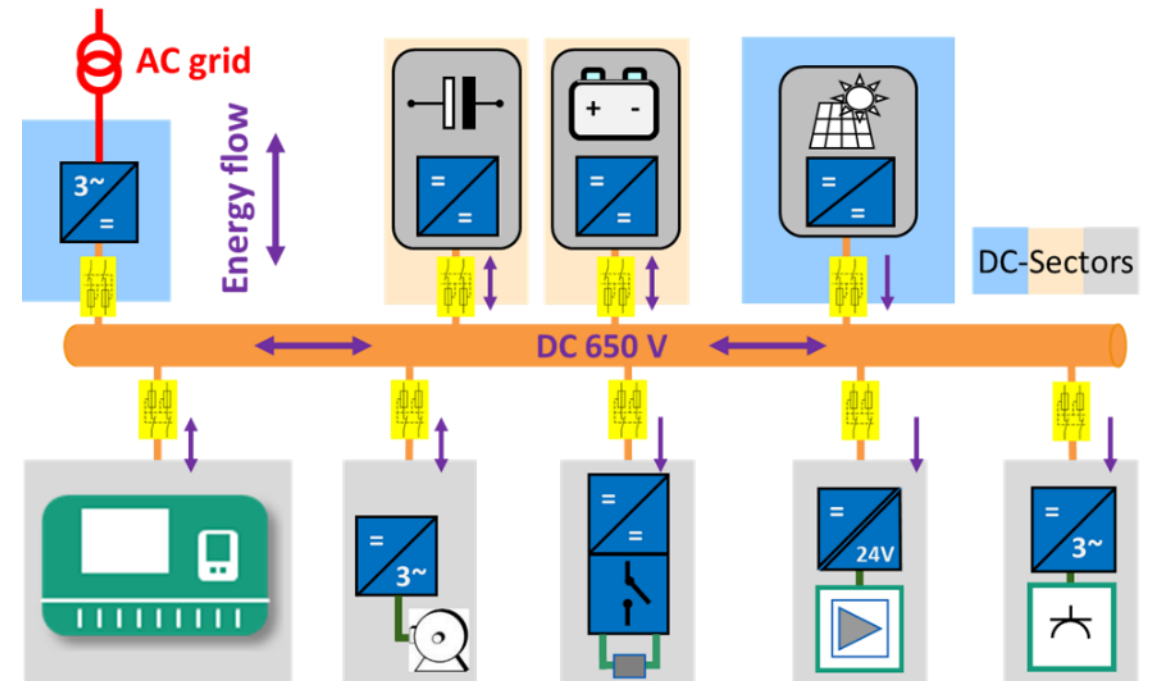

\*: Evaluated in model applications

## DC sectors organize the grid

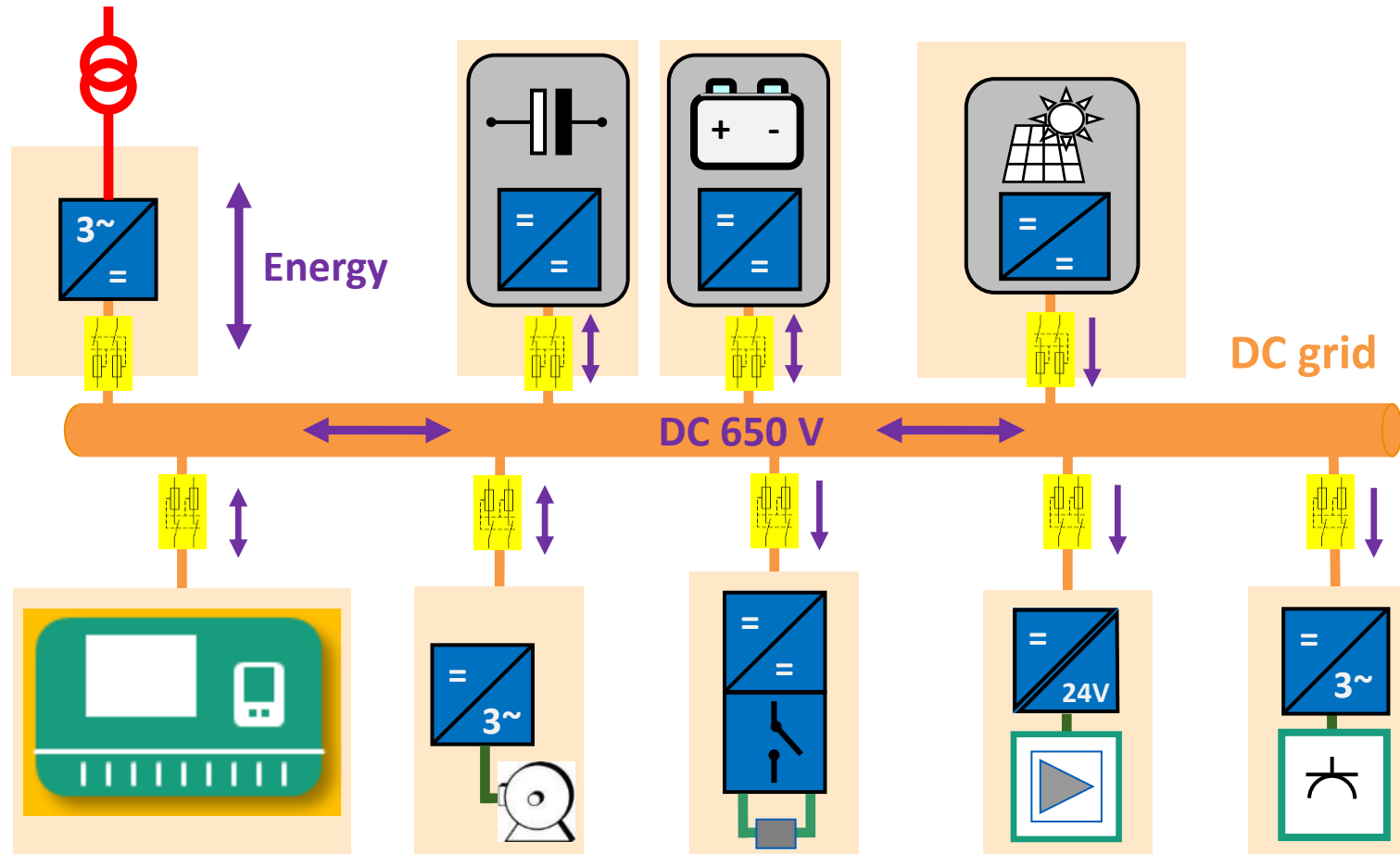

### DC sectors

- Build a logical unit
- Include components with strong functional dependencies to each other
- Provide sufficient capacity to suppress switch-frequency compensation processes from the DC-grids
- Are protected with a smart DC breaker



## Simplified power calculation AC vs DC

### • Power for AC

- Active power
  - $P = U \cdot I \cdot \cos(\varphi)$
- Reactive power
  - $Q = \sum_{n=1}^{\infty} [U_n \cdot I_n \cdot \sin(\varphi_{U_n} - \varphi_{I_n})]$
- Distortion power
  - $D = U \cdot \sqrt{I_2^2 + I_3^2 + \dots} = U \cdot \sum_{m=2}^{\infty} [I_m^2]$
- And everything three times for three-phase systems ...

### • Power for DC

- Active power  $P = U \cdot I$
- It really is that simple ...

- **In AC reactive power and distortion power need to be transmitted to the end user via cabling**
- **No such overhead in DC**

## Voltage bands – here for active infeed converters

- **In DC, voltage mirrors power balance**

- Load > supply → voltage drops ↘
- Supply > load → voltage rises ↗



- **Nominal voltage band → full operation 620 V – 750 V**

- Unlimited functionality

- **Overvoltage band 750 V – 800 V**

- Supply > demand → Shall not last longer than 60 s
- Active participants counteract the voltage deviation
- Storage devices charged, convenience loads are added

- **Emergency band (undervoltage) 400 V – 620 V**

- Overload condition → loads are reduced; storage supplies energy
- Devices may lose function & must resume function after voltage recovery
- Shall last less than 60 s

- **Switch-off limits: 400 V, 800 V**

- No operation → breakers disconnect

### Voltage bands

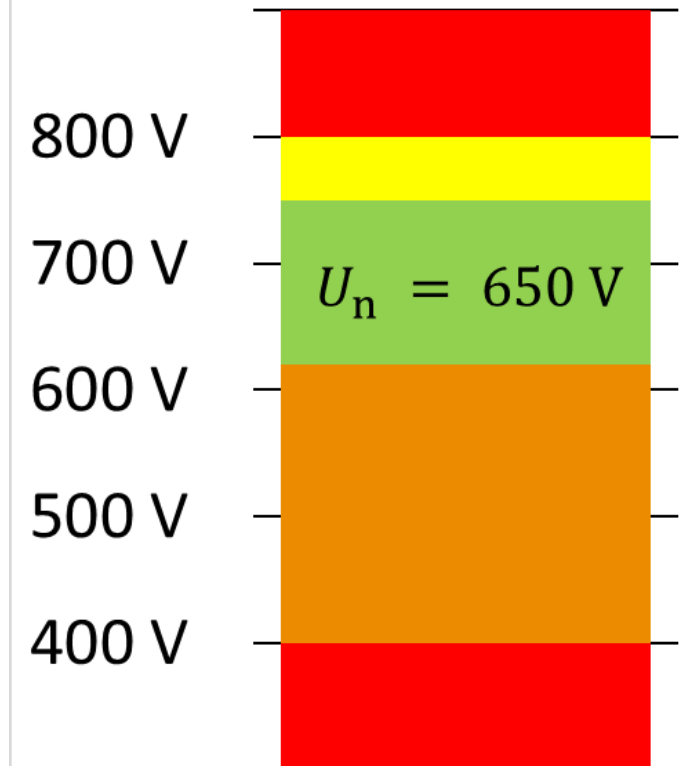

## Operating status – function of voltage and duration

Voltage level Bx and duration Sx determine operating status Ax

- **A7 Prohibited**
  - Damage very likely
- **A6 Overvoltage protection active**
- **A5 Overvoltage protection not active**
  - Devices may switch off
- **A4 Abnormal status**
  - Devices shall function dynamically
- **A3 Normal operation**
  - Full functionality
- **A2 Acute undervoltage**
  - Devices may reduce power
- **A1 Blackout status**
  - Switch off
  - Pre-charge on startup

Upper voltage limit U <sub>x</sub> of components for nominal voltage 540 V / 650 V		Voltage band	S1: t < 50 μs	S2: 100 μs ≤ t ≤ 1 ms	S3a: 1 ms ≤ t ≤ 5 s	S3b: 5 s ≤ t ≤ 60 s	S4: t > 60 s
Voltage ↑	U6: 2000 V	B7	A7	A7	A7	A7	A7
	U5: 880 V	B6	A6	A7	A7	A7	A7
	U4: 800 V	B5	A4	A5	A5	A7	A7
	U3: 750 V	B4	A3	A3	A3	A4	A5
	U2: 485 / 620 V	B3	A3	A3	A3	A3	A3
	U1: 400 V	B2	A4	A4	A2	A2	A2
		B1	A4	A2	A1	A1	A1

Time →

Based on IEC Technical Report TR63282

# Voltage stability and droop curves



## Grid voltage mirrors power balance

### a) Uncontrolled operation (basic network)

- No active control of the DC-voltage (operation with diode rectifier)

### b) Autonomous droop control

- Active feeders regulate their power depending on the level of DC voltage
- The characteristic is defined by a non-linear characteristic curve
- No communication required

### c) Droop control with communication

- Setting of the characteristic curve can be changed by a central control unit during operation
- Only slow communication required

### d) Central voltage control

- Central control unit provides the setup power values
- Fast communication required – real time control

Choosing the control method allows for simple as well as complex DC-grids with several sources

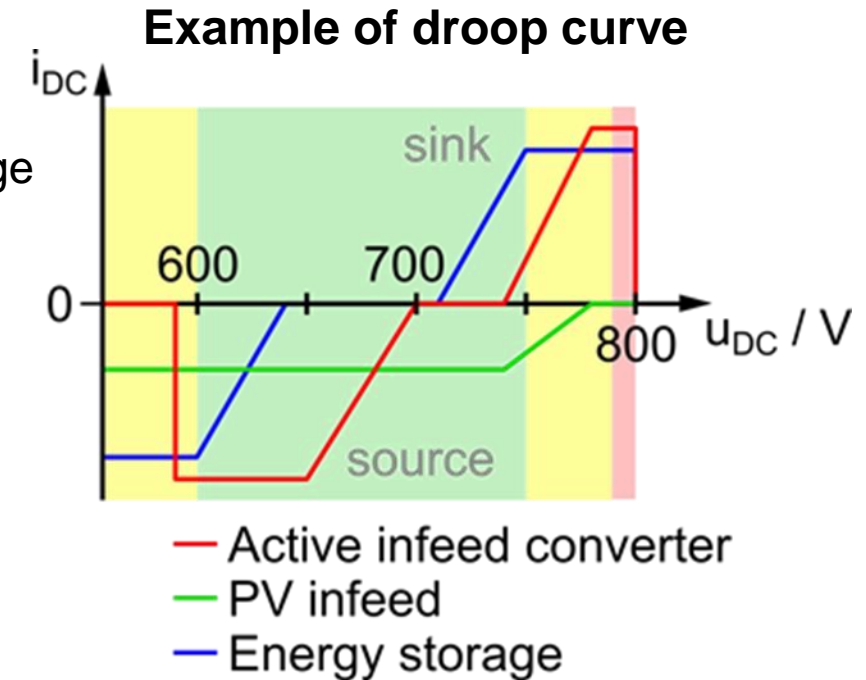

Same insulation!

## Cabling: Resource- and energy efficiency

### Example:

Supply of inverter driven three-phase motor 7.5 kW

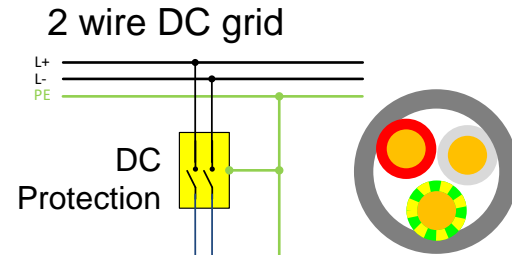
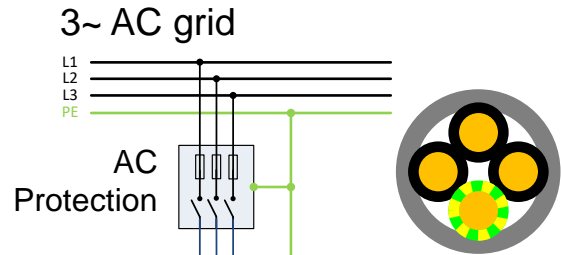

$$P_{AC} = P_{Motor} / (\eta_{Motor} \cdot \eta_{FU} \cdot \lambda) = 13.9 \text{ kVA}$$

$$I_{AC} = P_{AC} / (\sqrt{3} \cdot U) = 13.9 \text{ kVA} / (\sqrt{3} \cdot 400\text{V}) = 20 \text{ A}$$

$$P_{loss,AC}/l = 3 \cdot \rho / A_{AC} \cdot i^2 = 8.6 \text{ W/m}$$

$$P_{DC} = P_{Motor} / (\eta_{Motor} \cdot \eta_{FU} \cdot \lambda) = 8.7 \text{ kW}$$

$$I_{DC} = P_{DC} / U_{DC,min} = 8.7 \text{ kW} / 620 \text{ V} = 14.1 \text{ A}$$

$$P_{loss,DC}/l = 2 \cdot \rho / A_{DC} \cdot i^2 = 4.8 \text{ W/m}$$

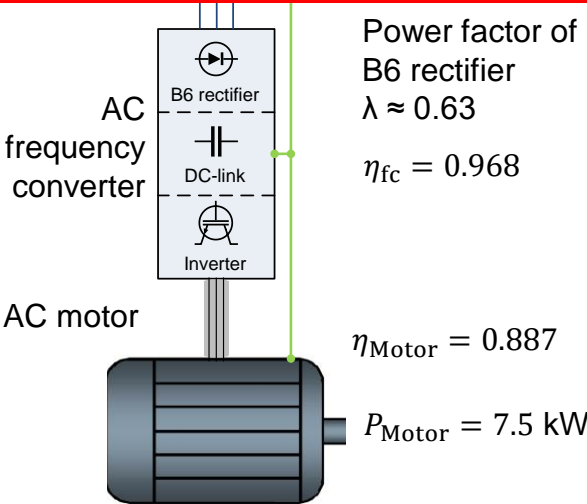

Power factor of B6 rectifier  $\lambda \approx 0.63$

$\eta_{fc} = 0.968$

$\eta_{Motor} = 0.887$

Specific electrical resistance of E-Cu at 30°C:  
 $\rho = 0,018 \text{ (}\Omega\text{mm}^2\text{)/m}$

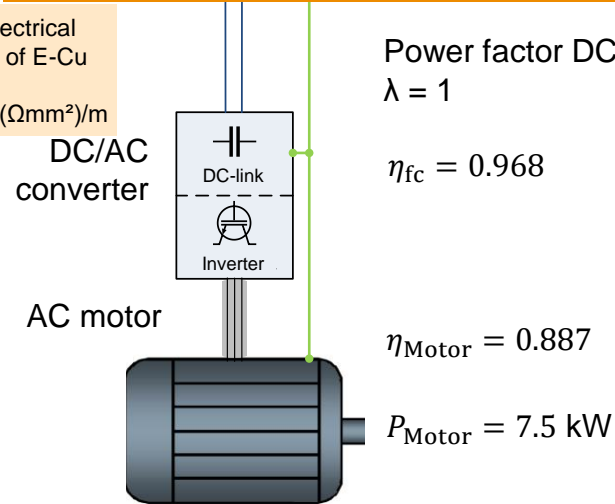

Power factor DC  $\lambda = 1$

$\eta_{fc} = 0.968$

$\eta_{Motor} = 0.887$

### AC: 20 A

- Cross section → 2.5 mm<sup>2</sup>
- Total copper: 4 × 2.5 mm<sup>2</sup> = 10 mm<sup>2</sup>

### DC: 14.1 A

- Cross section → 1.5 mm<sup>2</sup>
- Total copper: 3 × 1,5 mm<sup>2</sup> = 4.5 mm<sup>2</sup>
- 55% less copper for same power
- 45% less power loss in cables (R × i<sup>2</sup>)

Wiring type	B1	
Number of wires simultaneously loaded	2	3
Wire cross section in mm <sup>2</sup>	current in A	
1.5	17.5	15.5
2.5	24	21
4	32	28
6	41	36

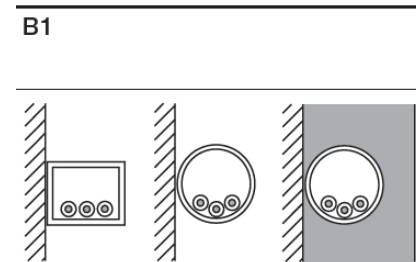

Permitted current in A @ 30°C ambient temp. acc. to DIN VDE 0298-4

# Smart DC Breakers: fast and reliable protection

- **Requirements**

- Fast operation – avoid voltage dips
- Bi-directional

- **Power semiconductors**

- IGBT + Diode
- (Mechanical breakers too slow)

- **Functions**

- Switching
- Overcurrent protection
- Isolation
- Detection of over- & undervoltage
- Pre-charging
- Communication

- **Properties**

- Fast ( $< 100 \mu\text{s}$  switch-off time)
- Low fault energy ( $\ll 1\%$  of mechanical breaker)

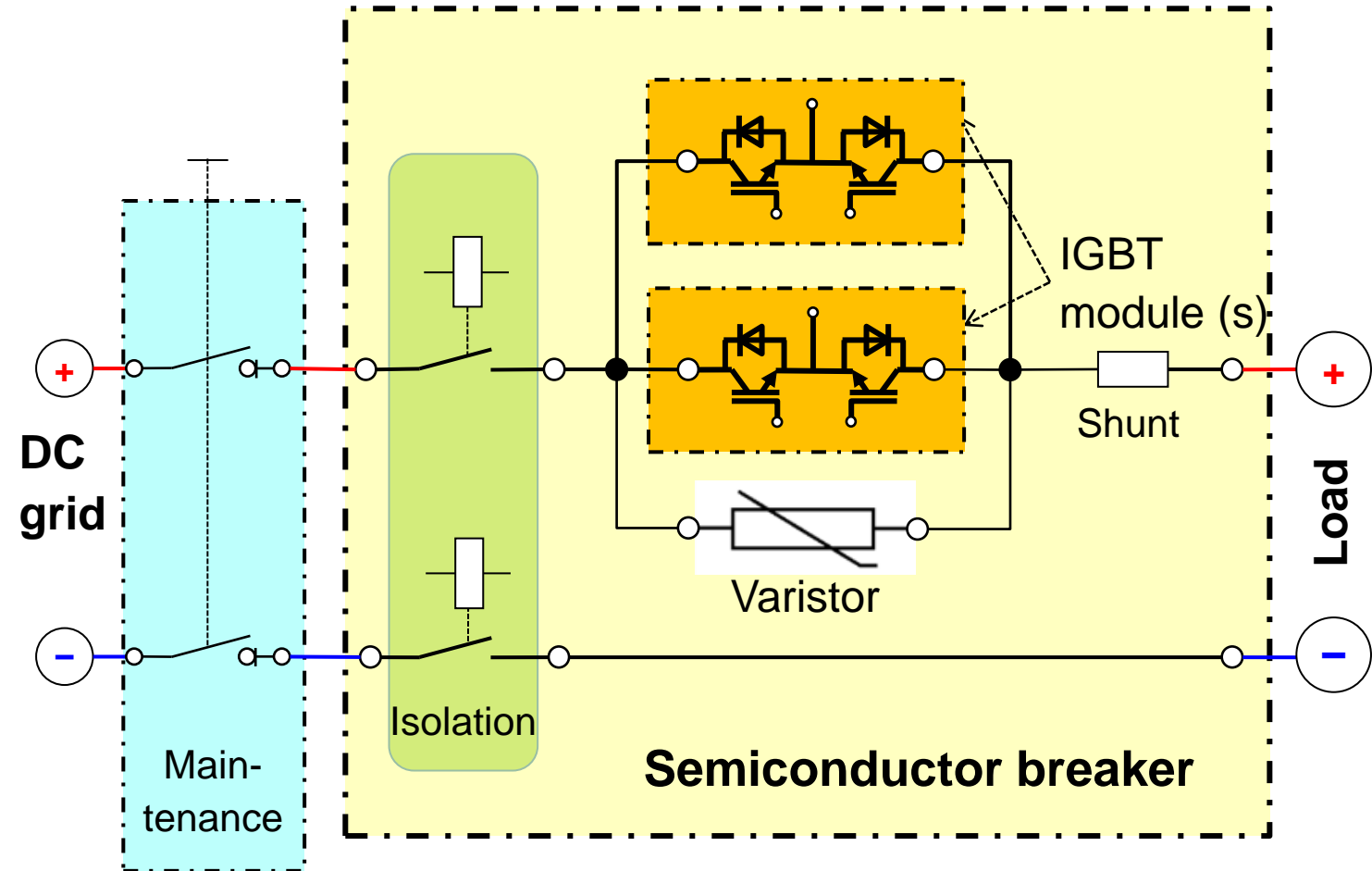

# Smart Hybrid Breaker reduces power loss

- **Mechanical contact conducts current**
  - low power loss
- **Power semiconductors interrupt**
  - Fast
- **Switch-Off procedure**
  - Actor opens mechanical contact → short arc
  - IGBT picks up the current (forward voltage < arc voltage) and switches off →
  - Varistor limits voltage
  - Isolation contacts open load- less and isolate
  - Coil limits current increase during short-circuit

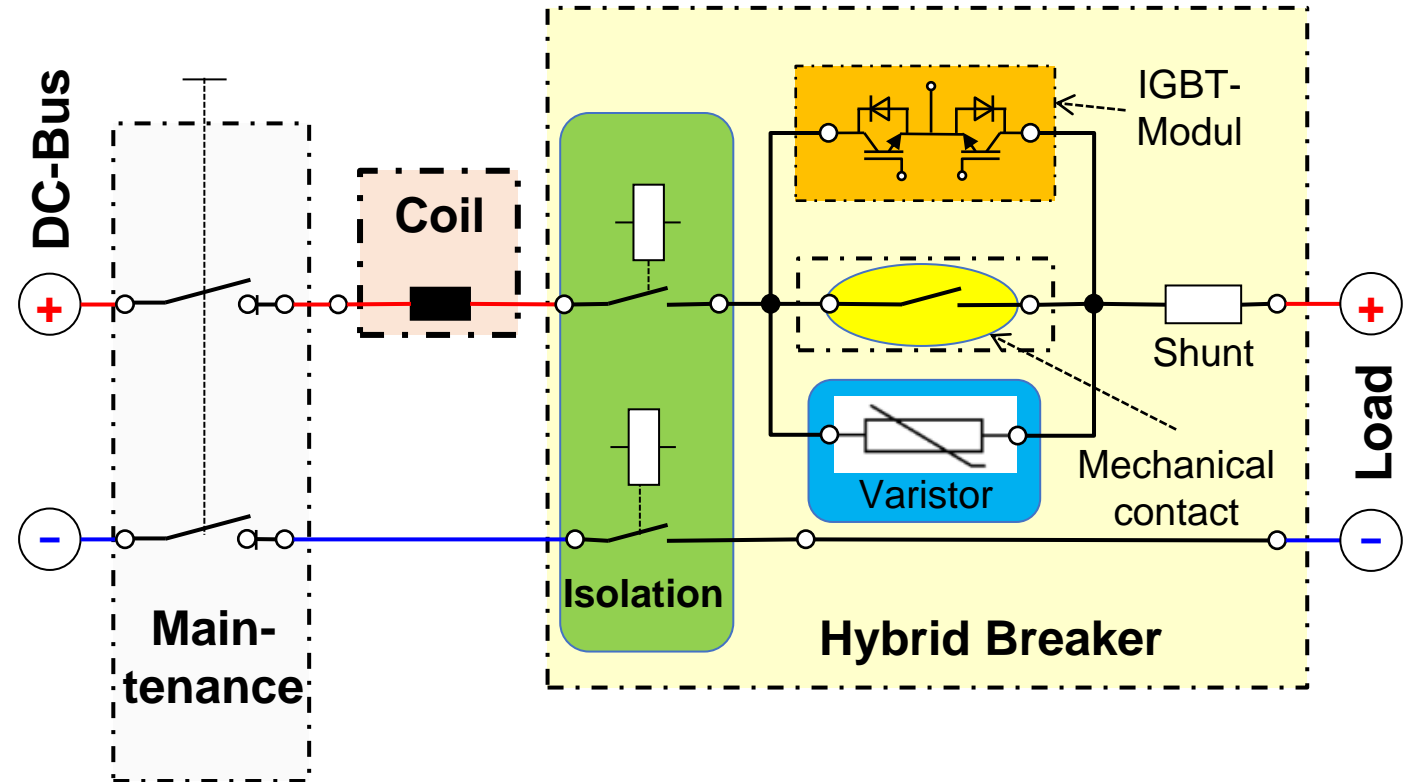

# Insulating materials for DC cables and DC housing materials

## • Basics electrical field E

- AC: E-field dependent on voltage and geometry
- DC: E-field is rectified and is subject to pronounced temperature

## • Impacts

- Different mechanisms between AC and DC
- Higher stress on the insulating material at DC possible:
  - Conductivity changes with temperature and moisture content
  - Polarization processes, field elevations, field migrations
  - Material behavior nonlinearly dependent on field distribution

## • DC-INDUSTRIE2

- Accelerated aging of selected typical AC insulating materials under DC stress at elevated temperatures in laboratory conditions
- Insulating materials: influence of plasticizers, fillers and the type of inner conductor (bare copper or tinned) on DC resistance

## • Results

- Suitable insulation materials for DC are available

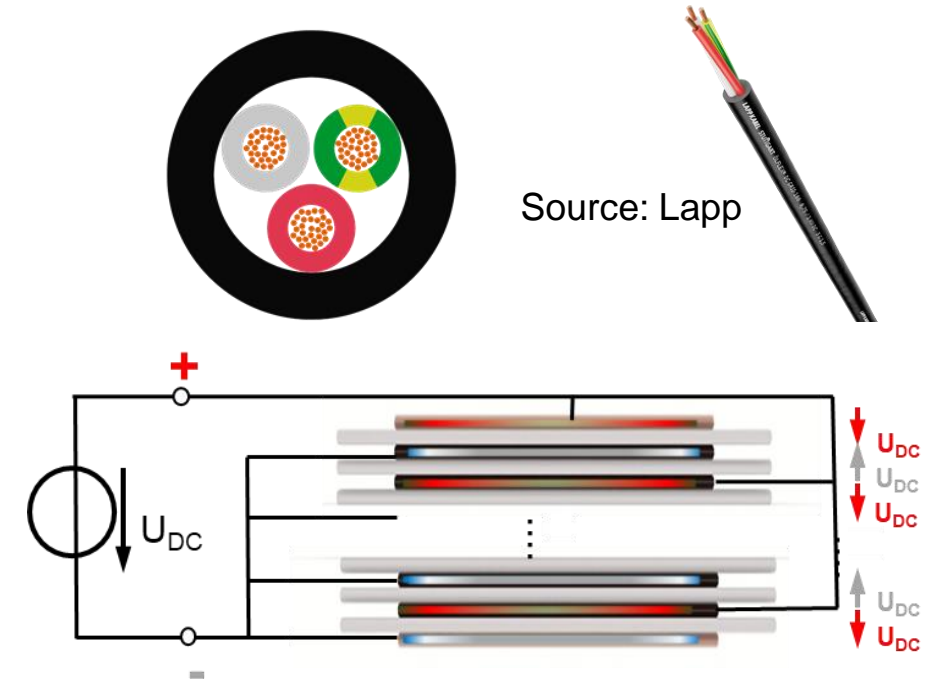



## Model applications of DC-INDUSTRIE

### • Mercedes-Benz

- Production cell with 4 robots
- Challenging energy demand (AI-welding)
- Continued from EU project AREUS



### • Mercedes-Benz

- Suspension track
- 5 individual carriers with slip rings
- Coupling of two applications



### • Homag

- Wood working machines
- Many loads
- Sensors & actors
- Integrated energy storage



### • KHS

- Beverage container handling
- Open concept
- > 30 drives



## Model applications of DC-INDUSTRIE

- **Mercedes-Benz**

- Production cell with 4 robots
- Challenging energy demand (AI-welding)
- Continued from EU project AREUS



- **Mercedes-Benz**

- Suspension track
- 5 individual carriers with slip rings
- Coupling of two production lines

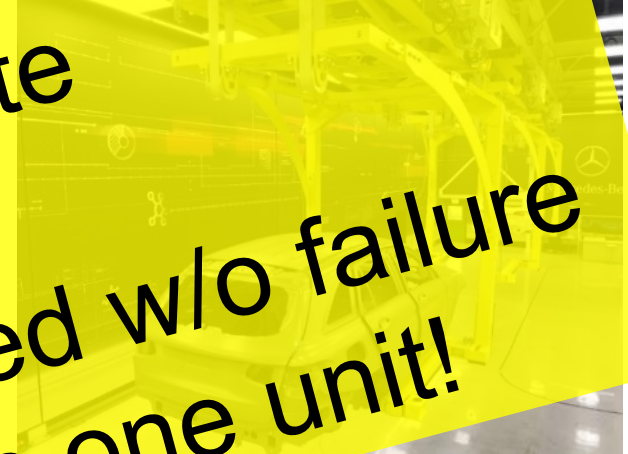

Devices from all partners collaborate

DC system concept confirmed

About 60 short-circuit faults cleared w/o failure

80% reduction of feed-in power in one unit!

- Homag
- world working machines
- Many loads
- Sensors & actuators
- Integrated
- energy storage



- KHS Beverage
- container handling
- Open concept
- > 30 drives



## Model applications of DC-INDUSTRIE2

1 / 4

### • BMW

- Car body production cell
- Focus
  - Energy distribution & storage
  - Energy feedback to grid
  - Switching and protection

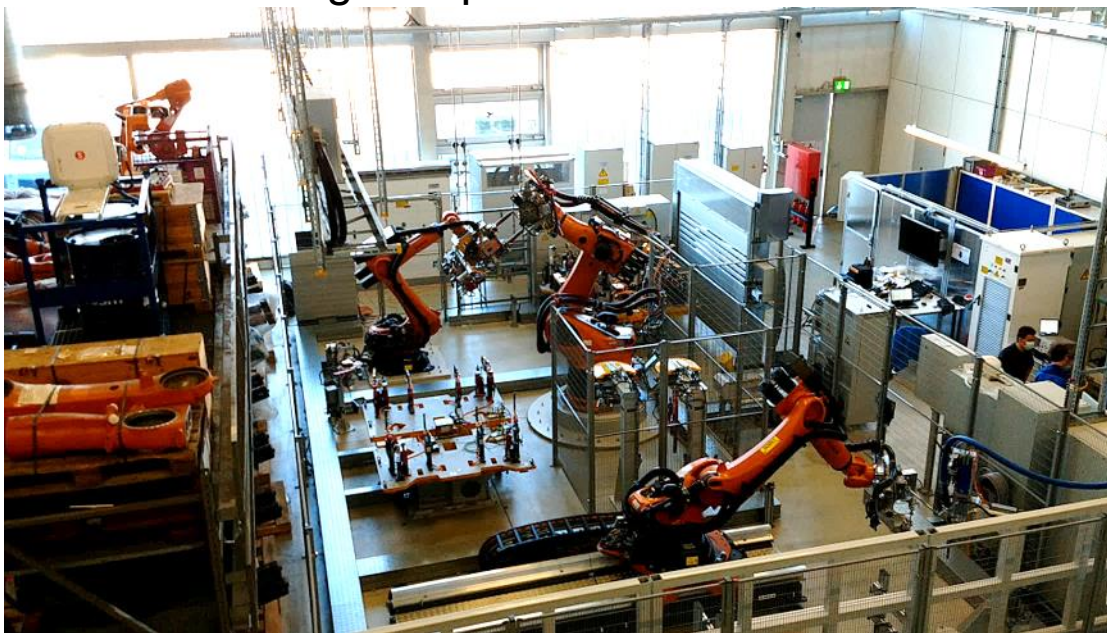

### • KUKA

- Test cell with 4 robots
- Focus: robot control

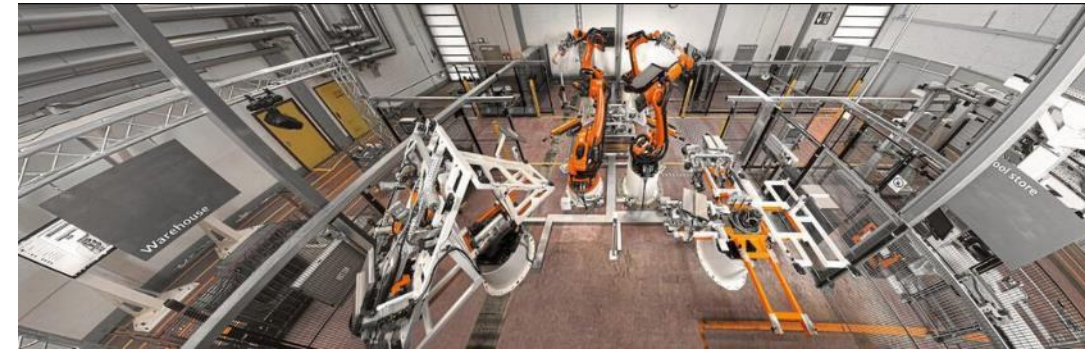

### • Fraunhofer IISB

- DC infrastructure in office building, EV charging

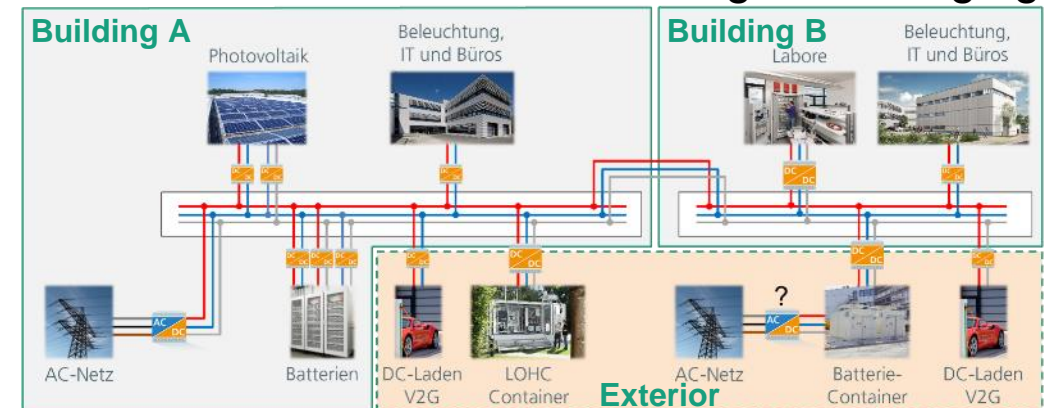

## Model applications of DC-INDUSTRIE2

2 / 4



### Mercedes-Benz Factory 56

- Large distances & power
- 222.000 m<sup>2</sup> production area
- 2 MW DC grid for hall infrastructure
- 1 MW solar energy, 5.7 MW peak
- Goal: CO<sub>2</sub>-neutral production

## Model applications of DC-INDUSTRIE2

3 / 4

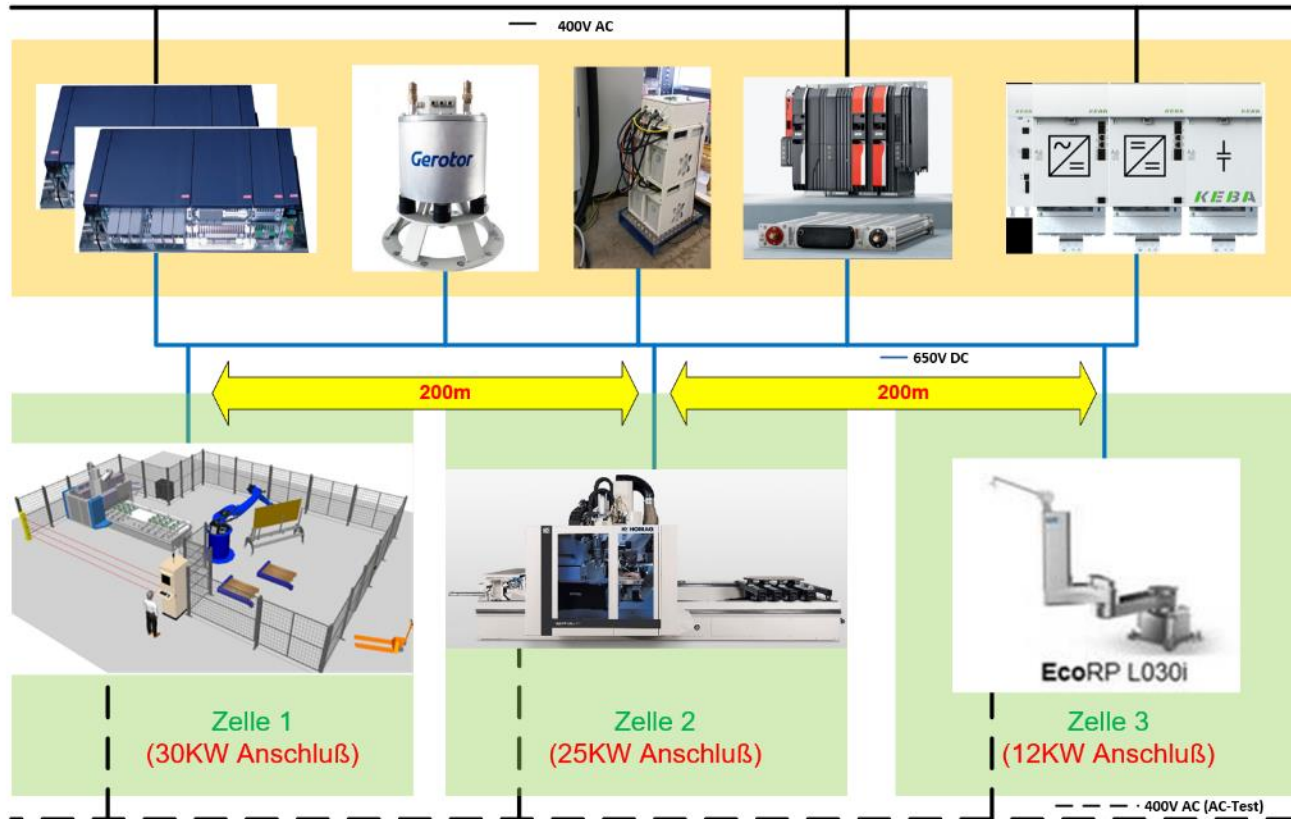

### • Homag

- Wood working machines
- Three applications spread out in a factory hall
- Setup
  - Multiple connections to AC grid
  - Several storage options
    - Flywheel
    - Capacitors
    - Batteries
- Focus
  - Influence of long cables on voltage dips during supply failure or faults
  - Coordination between several active infeed converters

		Projekt: DC-INDUSTRIE2 HOMAG Demonstrator				Datum	31.03.2021
		Zust.	Änderung	Datum	Name	Bearb.	Horbert Graf

## Model applications of DC-INDUSTRIE2

4 / 4

### • TH OWL

- Model electro-mechanical loads, up to 11 axes
- Storage
- Focus
  - Model dynamic behavior in real time
  - Test virtual machines in a DC environment
  - Test of multiple failure scenarios



### • Fraunhofer IPA

- Industrial power distribution
- AC-DC transformation
- Protection concept
- Parallel operation of AICs



Which adaptations are necessary for machines and systems for DC?

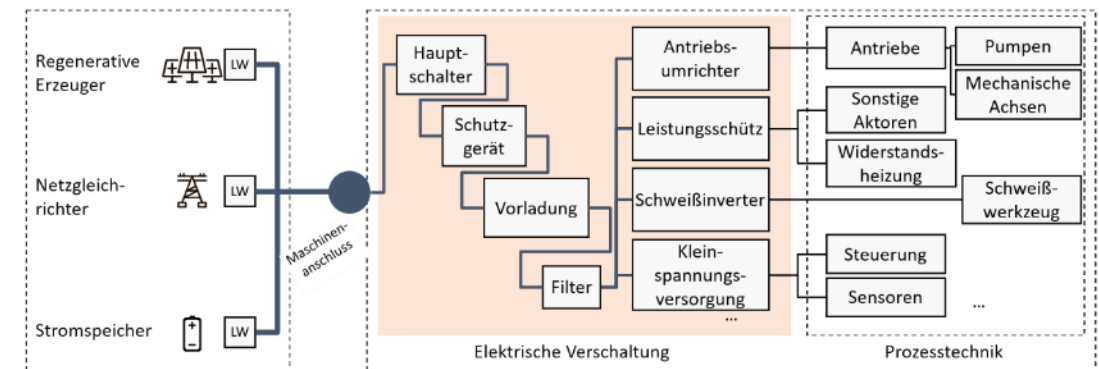

## More information and publications (examples)

- **DC-Industrie Homepage**  
[www.dc-industry.com](http://www.dc-industry.com)

- **Publications (excerpt)**

- [White paper](#)
- Several technical reports and papers
- Textbook *The DC-Factory*, Hanser Verlag, 2021  
<https://www.hanser-kundencenter.de/fachbuch/artikel/9783446471740>
- English and German version available

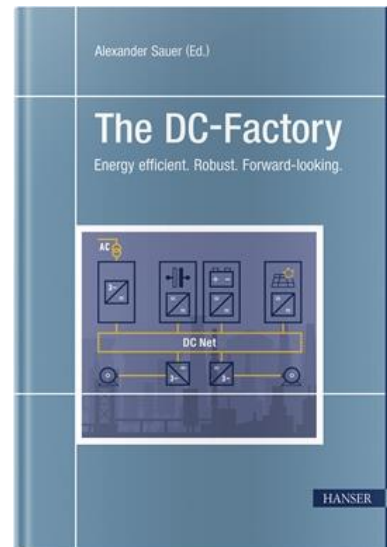

- **Computer & Automation**  
[4 article technical paper series](#)

- **Hannover Messe 2022**



## Hannover Messe 2022 Presentations

<https://experience.dc-industrie.zvei.org>



RIE 4.0



Start Topics ▾

DC-INDUSTRIE: Open DC Grid for Sustainable Factories

Click for more info

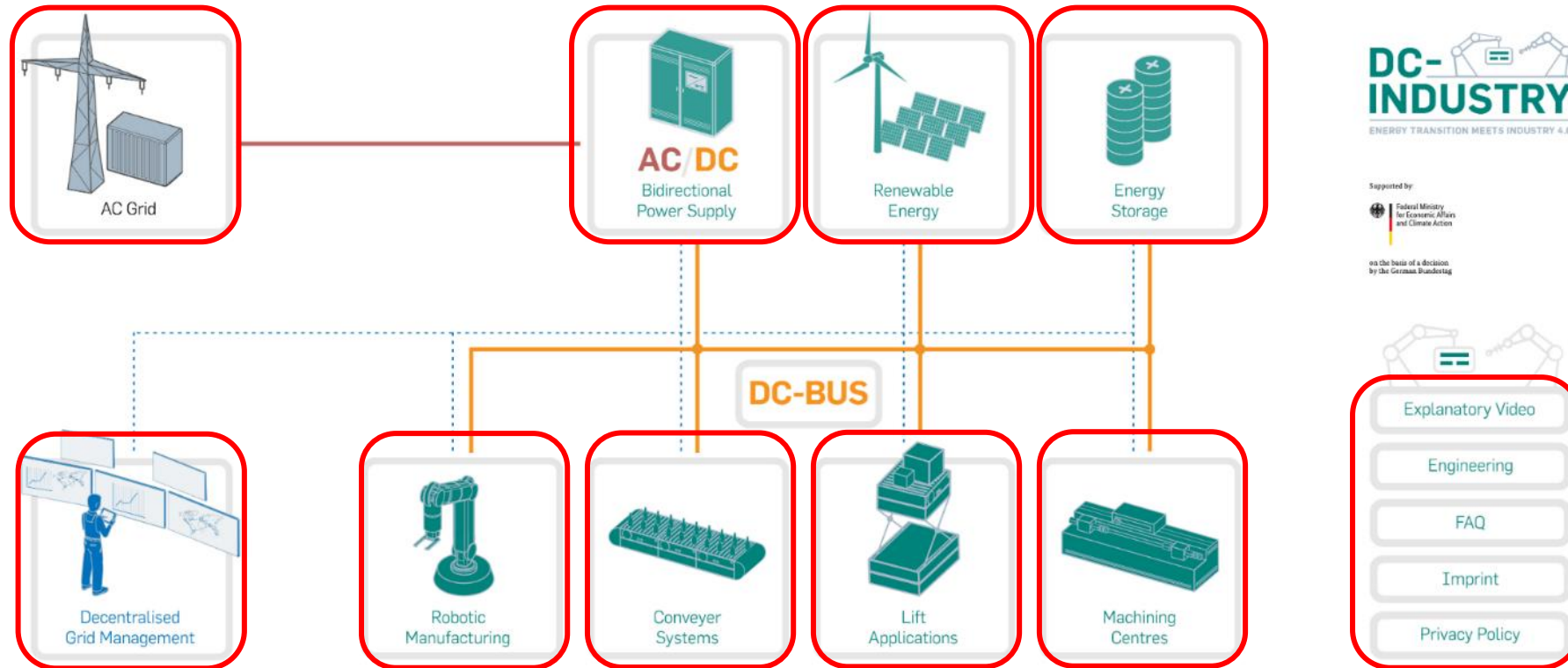

Supported by  
Federal Ministry  
for Economic Affairs  
and Climate Action  
on the basis of a decision  
by the German Bundestag

- Explanatory Video
- Engineering
- FAQ
- Imprint
- Privacy Policy



# Benefits of DC & DC-INDUSTRIE

1. Open system
2. Efficient integration of green energy
3. Resource efficiency
4. Lower energy consumption
5. Reduced feed-in power
6. Increased system availability

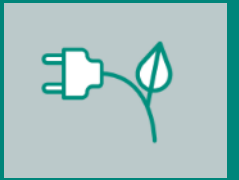

## Part of the committed DC-INDUSTRIE team



Lemgo, Sep. 2019

## Project partners – [www.dc-industry.com](http://www.dc-industry.com)

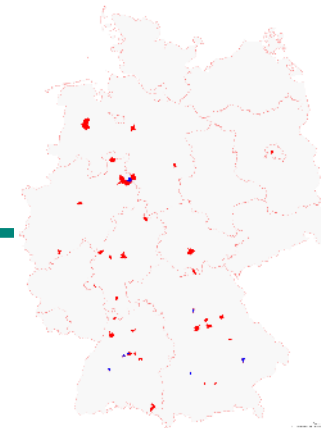

Supported by:



Federal Ministry  
for Economic Affairs  
and Climate Action

on the basis of a decision  
by the German Bundestag



Powering Business Worldwide



Rolls-Royce  
Motor Cars Limited



**Associated partners:** ABB Stotz-Kontakt; AMK Arnold Müller; Audi; Bauer Gear Motor; Bender; Danfoss; DEHN; ESR Pollmeier; Gerotor; Harting; JEAN MÜLLER; KUKA; LEONI; Maschinenfabrik Reinhausen; Paul Vahle; Puls; Rittal; SEW-PowerSystems; Siemens; TU Ilmenau; Wöhner